

Machine Room Less Passenger Elevator 无机房乘客电梯

EKW50/EKW55

本书为一般信息类出版物，我们保留随时更改产品设计和说明的权利。本书的任何字句，无论其字面意思或含义，对于任何产品及产品的用途和质量，或者任何购销合同条款文的表述与更改均不承担任何责任。
(产品效果图为电脑制作仅供参考，具体以实物为准)

General information for book publication, we reserve the right to change product design and function. Any words of this book, regardless of whether in print or otherwise, for any purpose and quality of product and the product, or any expression and changes of purchase and sale contract provisions shall not bear any responsibility.
(The product are for reference only, specifically in kind prevail)

EPSS-2017 第一版

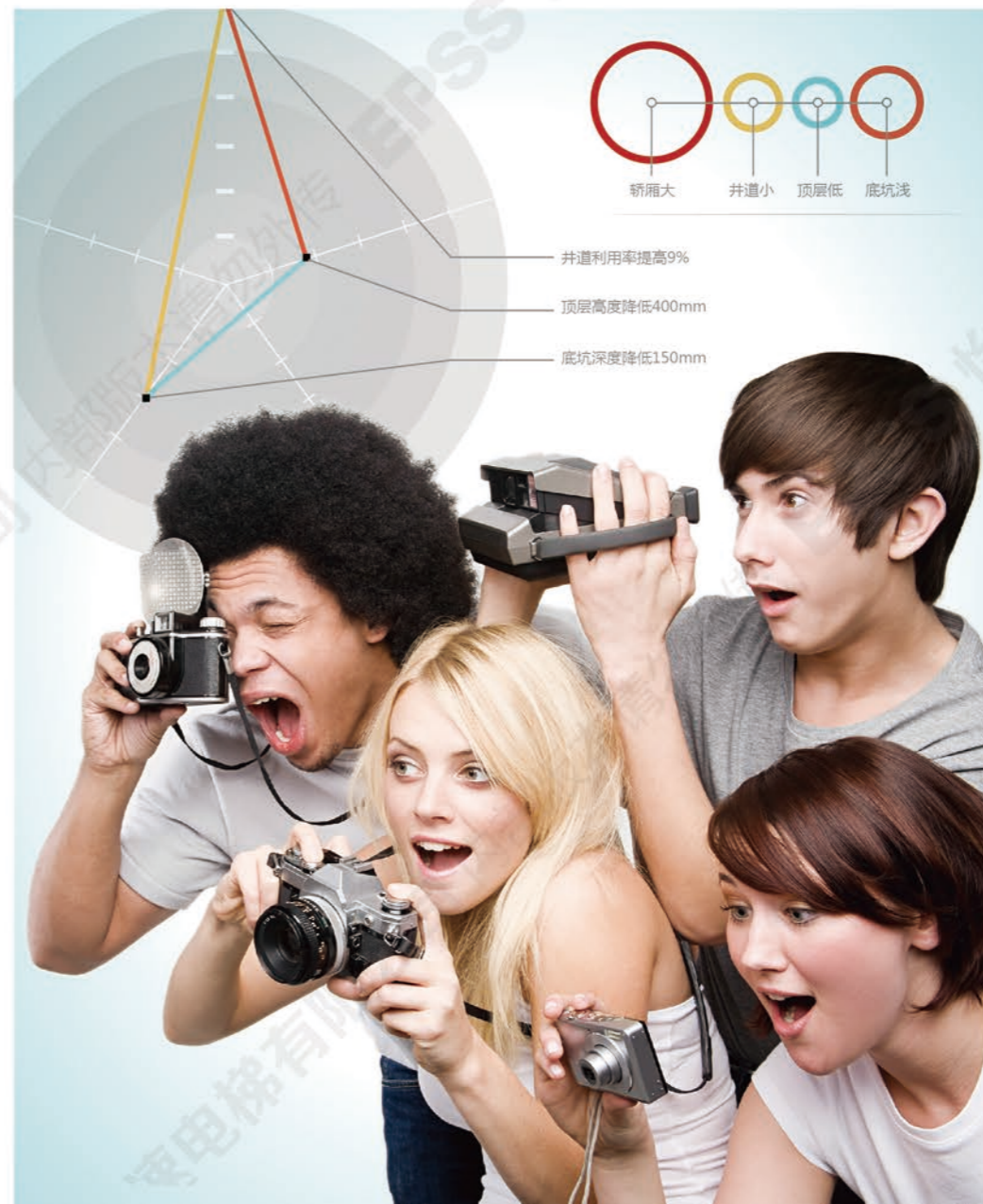

井道利用率提高9%
顶层高度降低400mm
底坑深度降低150mm





电梯
elevator



安全
safety



完美
perfect

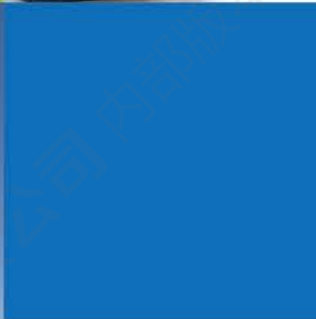

服务
service



承载安全 传递微笑



Bearing security
Pass a smile

更安全的承载
是我们的使命

Safer bearing is our mission



About Us 公司简介

每天，全球有60多个国家和地区享受到怡达快速电梯带来的安全、高效、节能的上下体验。

致力于专业从事电梯研发、设计、制造、销售、安装、维保，中美合资怡达快速电梯有限公司是国内较早取得电梯A级制造许可证的企业之一。

如今，怡达快速电梯在总占地面积约11万平方米的新厂区，引进当今世界最先进的自动化生产设备，建立起世界一流的电梯专业工厂，制造全球的智选电梯。

“提供完美的电梯安全与服务”，不再只是一句口号，而是落实在电梯选材、设计、生产、检测、安装、维保的每个环节，为客户提供具有国际水准的适配产品和卓越服务。

Everyday, more than fifty countries in the world can enjoy the perfect ride experience, which is safe, efficient, energy saving from Yida Express Elevator.

Devoting itself to professional working in elevator research, design, manufacturing, sale, installation and maintenance, Sino-American Joint Venture Yida Express Elevator Co.Ltd. is one of the earliest companies in China, which achieve A-class elevator manufacturing license.

Nowadays, Yida Express Elevator has moved to the new factory, which covers an area of about 110000㎡.The company has imported the most advanced high automation level production equipments and built first-class elevator professional factory. It devotes to manufacturing intelligent elevators supplied to all over the world.

“Provide prefect elevator safety and service” is not just a slogan. Instead, it is implemented in every production step such like elevator material selection, design, manufacture, inspection, installation,maintenance. It provides compatible product with international standard and excellent service.

EKW50/EKW55 Technological superiority 技术优势

120m 最大行程
Max travel: 120 m

2000Kg 最大载重
Max capacity: 2000 kg

2.0m/s 最大速度
Max speed: 2.0 m / s

Intellectual property products

2 patents for inventions

Patent No. ZL201410550751.0
ZL201510457757.8

4 patents for utility models

Patent application No. 201720750917.2
201720875599.2
201720900196.9
201720899071.9

Smaller shaft size, bigger cabin size

EKW50/EKW55 Machine room-less passenger elevator only needs independent hoist space; no need to set the machine room and complex openings, and civil work construction requirements is simpler.it maximizes the compression of the overhead and pit depth to improve the utilization of the shaft space, so as to maximize the car size within the same shaft size. It greatly improves the utilization of building area while reducing construction costs, so that architectural design becomes freer.

Smaller overhead, smaller pit

EKW50/EKW55 machine roomless passenger elevator optimize the car top and bottom structure on the basis of compliance with National Standard, compared with ordinary machine room-less passenger elevator, utilization rate of the shaft space is improved.

专利产品

发明专利2项

发明专利号: ZL201410550751.0
ZL201510457757.8

实用新型专利4项

专利申请号: 201720750917.2
201720875599.2
201720900196.9
201720899071.9

井道小、轿厢大

EKW50/EKW55无机房乘客电梯只需独立的井道空间，无需设置机房，无需建筑预留复杂洞口，土建要求更简单，更加提高了井道利用率，做到同井道轿厢最大化,极大提高建筑面积使用率同时降低建筑成本，使建筑设计更加的自由。

顶层低，底坑浅

EKW50/EKW55无机房乘客电梯在满足国标的同时优化轿顶、轿底结构，与普通无机房客梯相比最大化压缩顶层高度与底坑深度，井道整体利用率提高。

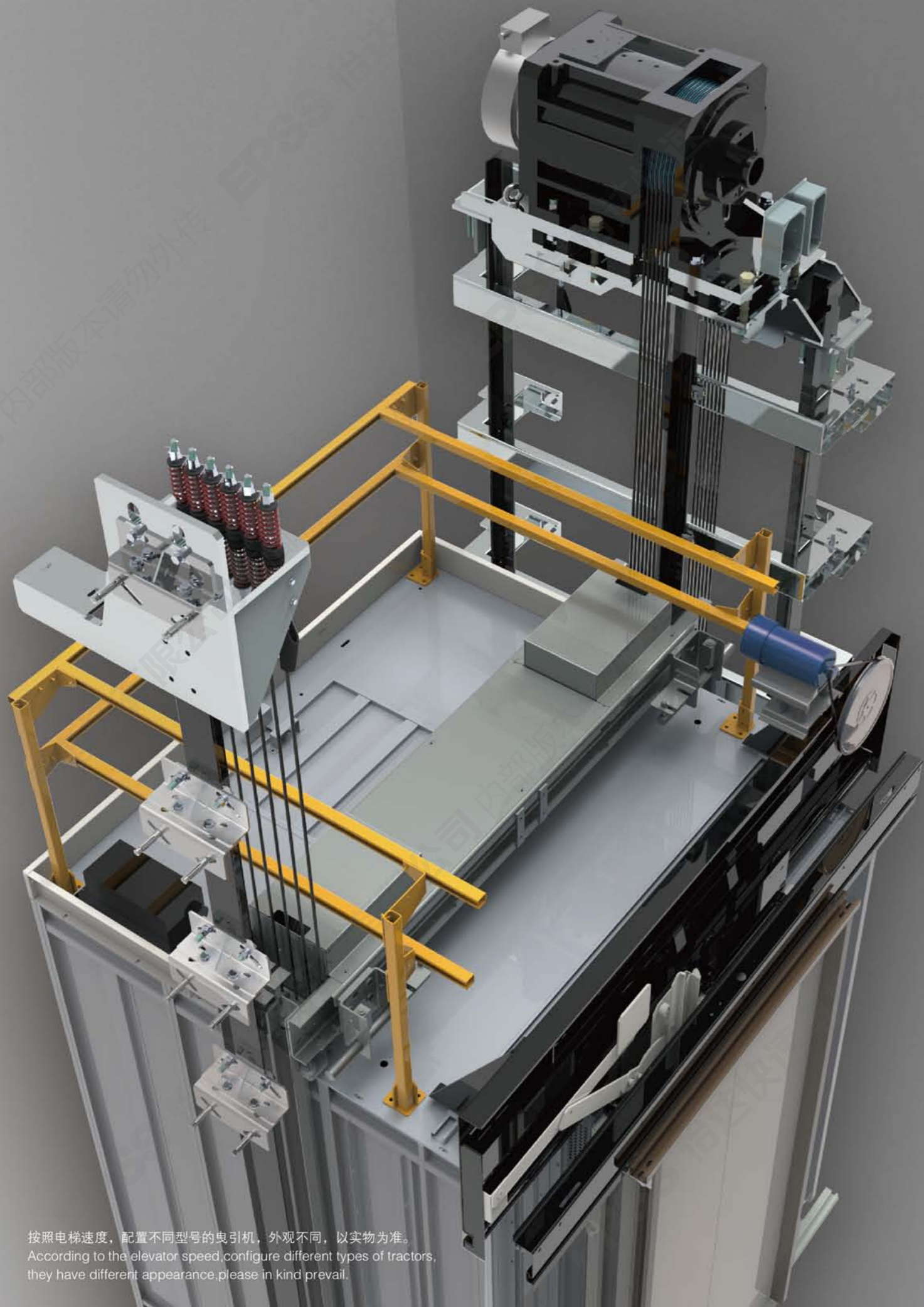

按照电梯速度，配置不同型号的曳引机，外观不同，以实物为准。
According to the elevator speed, configure different types of tractors, they have different appearance please in kind prevail.

Passenger Elevator(MRL)

无机房 乘客电梯



平稳运行

EKW50/EKW55曳引机采用内转子双支撑结构，受力结构更均匀合理，制动力矩大，挂载后磁路气隙无变化，运行更平稳。

安静舒适

制动器采用盘式轴刹双摩擦幅结构，转矩脉动小，吸合释放噪声低，缓解环境噪音，提升电梯运行舒适性。

稳定可靠

曳引机达到高防护等级，有效防止异物及防水，确保产品稳定，延长使用寿命。

安全保障

EKW50/EKW55系列所有产品部件，通过公司由国家认可委认证的CNAS检测中心认证，严格符合电梯行业的所有标准与要求，突显高度可靠性，关怀乘客的安心乘梯体验。

安装便捷

EKW50/EKW55无机房乘客电梯创新结构设计，对重导轨采用实心导轨，简化导轨支架的安装方式，减少螺栓的使用量，降低了工地现场的安装难度，节省施工成本。

Running smoothly

EKW50/EKW55 machine room-less elevator traction machine use inner-rotor double support structure, the force structure is more uniform and reasonable; the braking torque is large, with load on motor, magnetic field air-gap has no change, running is smoother.

Quiet and comfortable

Brake is disc type with double-side friction structure, torque ripple is small, brake close and release noise is low. Easing the environmental noise and enhancing the elevator running comfort.

Stable and reliable

Achieve high protection level. It effectively prevents foreign matter and waterproof to ensure product stability and extend the service life.

Security assurance

All components of the product line EKW50/EKW55 series are certified by the CNAS Testing Center of Yida Express Elevator. They strictly comply with all the standards and requirements of the elevator industry, it means high reliability and concerning about the comfortable ride experience of the passengers.

Convenient installation

The compact machine room passenger elevator-EKW50/ EKW55 innovates structure design and adopts solid counterweight guide rail, simplifies the installation of rail bracket, reduces the use amount of bolts, so it reduces the difficulty of installation on site and saving construction cost.



高集成智能控制系统

采用双32位CPU，主从CPU相互控制，更大程度提高了数据处理速度。系统内设置的高智能微机模块，对电梯运行实施最安全、精确、高效的管理控制。

Highly integrated and intellectual control system

Double 32 bit CPU, mutual control between main CPU and sub CPU, increases the speed of data processing to a great extent. Moreover, the highly intellectual micro-computer module inside our systems guarantee the most secure, accurate, and effective control to our elevator.



Intelligent System 智能系统



1 特色安全功能

■ 抱闸力自动检测

电梯制动器长时间使用造成的闸皮磨损会导致其制动力下降，系统将适时按“标准”对其进行制动力的检测及报警提示。

■ 曳引绳滑动检测

实时检测电梯运行（位置）偏移量。超出允许值时，电梯减速，停止运行（就近平层）。

2 远程监控

■ 智能终端异地监控

在监控中心或远程的智能手机可实时观测异地电梯的参数及运行状态，且能通过数据流传输语音、图片、视频等。

3 智能分析

■ 故障分析专家系统

自动获取故障发生时的电梯状态信息。后台分析，处理。显示分析结果并给出故障描述，安全可控。

4 智能IC卡系统

根据用户的需求，可配置IC卡智能管理系统，对电梯实行权限管理，提高楼宇管理的安全性。

5 群控管理

采用高性能的群控管理系统，可以实现3-8台电梯群控功能，对厅外召唤的应答作出合理的统筹处理，有效缩短了候梯时间，实时适应乘客流量的变化。

Safety Function

■ Brakeage Automatic Detection

Brake rubber abrasion, which is caused by elevator brake using for a long time, will lead to decline the brake force. System will detect the brake force and alarm remind according to the "Standard".

■ Hoist rope sliding detection

Offset of running location should be detected in real time. Elevator will slow down and stop running when the steel rope slipping exceeds the allowable value.(stopping on the nearest floor)

Remote monitoring

■ Intelligent terminal remote monitoring

It can monitor the elevator parameters and running condition in the monitor center or remote intelligent cellphone. Meanwhile, it can transfer voice, pictures and videos by data stream.

Intelligent analysis

■ Failure analysis expert system

To acquire the elevator state information automatically when it is failure, then system will make analysis and dispose. It will display the analysis result and describe the failure.

Intelligent IC card system

IC card can be configured according to user requirements, IC card can execute permissions management for elevator, which improves the safety of the building management

Group control management

High performance group control management system enable 3-8 sets of elevators to carry out the function of group control, which response and deal with the hall call reasonably and reduce the passenger's waiting time effectively. The system adapted to the change of passenger flow real-time.



节能运行

EKW系列在实现卓越性能的同时消耗更少的能源。专业测试结果显示，该系列产品达到了能耗标准VDI4707认可的“A”绿色等级范围，即最佳等级能效认证。VDI4707于2009年3月欧洲发布的全球首个电梯能效等级认证体系，是电梯能效系统的重要依据。

EKW series consume less energy and have achieved superior performance. The professional test results show that the energy consumption of this series of products has reached grade A which is in green level range according to the energy efficiency standard VDI4707, it is the optimal grade of energy efficiency certification. VDI4707 was released in March 2009 by Europe, it is the world's first lifts energy efficiency certification system and also the important basis for lifts energy efficiency system.



降低城市建筑碳排放！

怡达快速电梯严格遵循美国快速电梯全球产品研发标准，采用世界领先的先进技术和设计理念，运行高效、节能环保，为您的未来提供完美运载。

Reduce the building carbon emissions

EPSS elevator complies with the Products Research & Development standard of American Express Elevator Co., Ltd. strictly. With advanced technology and design concept, featuring effective running and energy-conservation and environment-protection, it provides a perfect carrier for your future.

Energy saving Environmental protection 节能环保

选用稀土材料，将同轴传动技术、数字变频技术和群组电脑组合控制技术充分融合，运行成本小，能量散失低，比一般传统技术可节省能源33%以上。无齿轮曳引机无需更换油脂，无油渍污染，低噪音。

Using the rare earth materials and combined with coaxial transmission technology, digital VF technology and group control technology, the running cost and energy dissipation are low, it can save more than 33% energy than traditional machines. Gearless traction machine don't need to change the grease, no grease stain pollution and low noise.

可选配能量反馈系统，将消耗在制动电阻上的能量转换为电能，供楼宇内其他电梯或用电设备使用，我们的“绿色发电机”可以节约30%的能耗，增添节能环保效益。

As an optional function, the energy regenerate system can converse the braking energy into electrical energy which can be supplied to other elevators or electrical equipment in the building. Our "green generator" can save 30% energy consumption and add benefits through energy saving and environment protection.

轿内LED照明装置，光线柔和明亮，热度低，安全、高效、无辐射，有利于长效使用，且系统在电梯空闲未使用状态下自动熄灭，绿色环保。

The LED lighting device in the car is beneficial for long-term use. Its light is soft, bright, low-heat, safe, efficient and no radiation. When the elevator is in idle time, the light will power off automatically, it is green and environmental protection.

可选用先进的环保技术，通过等离子使空气中的PM2.5等微尘形成分子团下沉落地，使细菌生存能力下降或致死，定时除菌，净化空气，提供绿色健康的电梯乘坐环境。

Choosing the advanced environmental protection technology. Through the chemical reaction between the active substances in plasma and micro-organisms, it can reduce the producing capacity of the bacteria or kill them, at the same time, it can decompose the pollutants to small molecules inorganic. Through the sterilization and Purifying air, this function can provide elevator with the green healthy riding environment.



Permanent
Magnetic Power
永磁动力



Regeneration
system
能量反馈系统



LED Automatic
Lighting
LED自动照明



Sterilization Function
洁净抗菌功能



前视角

EX-W01A 标准配置

吊顶: EX-J110 铝合金框架+亚克力+LED灯
 操纵箱: EX-AC96A
 显示: 段码LED
 后壁: 发纹不锈钢面
 侧壁: 发纹不锈钢面
 地坪: EX-DB101 石塑地板(可选配)
 轿门: 发纹不锈钢面
 前壁: 发纹不锈钢面

EX-W01A Cabin (Standard)

Ceiling: EX-J110 Aluminium alloy frame, acrylic, LED lighting
 C.O.P.: EX-AC96A
 Indicator: LED display
 Rear wall: Hairline stainless steel
 Side wall: Hairline stainless steel
 Flooring: EX-DB101 Vinyl tile (optional)
 Cabin door: Hairline stainless steel
 Front wall: Hairline stainless steel

EX-W02 轿厢 (选配)

吊顶: EX-J112 铝合金框架+镜面不锈钢+亚克力+LED灯
 操纵箱: EX-AC97A 一体式操纵箱
 显示: 段码LED
 后壁: 和纹不锈钢面+镜面不锈钢面
 侧壁: 和纹不锈钢面
 地坪: EX-DB108 (耐磨 PVC)
 轿门: 和纹不锈钢面
 前壁: 和纹不锈钢面

EX-W02 Cabin (Optional)

Ceiling: EX-J112 Aluminium alloy frame, Mirror stainless steel, acrylic, LED lighting
 C.O.P.: EX-AC97A Integral C.O.P.
 Indicator: LED display
 Rear wall: Irregularly-lined stainless steel, mirror stainless steel
 Side wall: Irregularly-lined stainless steel
 Flooring: EX-DB108 (wear resistant PVC)
 Cabin door: Hairline stainless steel
 Front wall: Hairline stainless steel



后视角



后视角

EX-W03 轿厢 (选配)

吊顶: EX-J113A 玫瑰金镜面不锈钢框架+亚克力+LED灯
 操纵箱: EX-AC97A 一体式操纵箱
 显示: 段码LED
 后壁: 玫瑰金镜面蚀刻面
 侧壁: 玫瑰金镜面蚀刻面
 地坪: EX-DB13 (耐磨 PVC)
 轿门: 玫瑰金喷砂不锈钢面
 前壁: 玫瑰金喷砂不锈钢面

EX-W03 Cabin (Optional)

Ceiling: EX-J113A Mirror stainless steel (Rose gold) frame, acrylic, LED lighting
 C.O.P.: EX-AC97A Integral C.O.P.
 Indicator: LED display
 Rear wall: Mirror etched stainless steel (Rose gold)
 Side wall: Mirror etched stainless steel (Rose gold)
 Flooring: EX-DB13 (wear resistant PVC)
 Cabin door: Sandblasted stainless steel (Rose gold)
 Front wall: Sandblasted stainless steel (Rose gold)

EX-W05 轿厢 (选配)

吊顶: EX-J111 铝合金框架+亚克力+LED灯
 操纵箱: EX-AC97A 一体式操纵箱
 显示: 段码LED
 后壁: 镜面不锈钢面+彩纹钢板 (纹理可选)
 侧壁: 镜面不锈钢面+彩纹钢板 (纹理可选)
 扶手: EX-FS01B 镜面不锈钢
 地坪: EX-DB112 (耐磨 PVC)
 轿门: 发纹不锈钢面
 前壁: 发纹不锈钢面

EX-W05 Cabin (Optional)

Ceiling: EX-J111 Aluminium alloy frame, acrylic, LED lighting
 C.O.P.: EX-AC97A Integral C.O.P.
 Indicator: LED display
 Rear wall: Mirror stainless steel, laminate metal (optional)
 Side wall: Mirror stainless steel, laminate metal (optional)
 Handrail: EX-FS01B Mirror stainless steel
 Flooring: EX-DB112 (wear resistant PVC)
 Cabin door: Hairline stainless steel
 Front wall: Hairline stainless steel

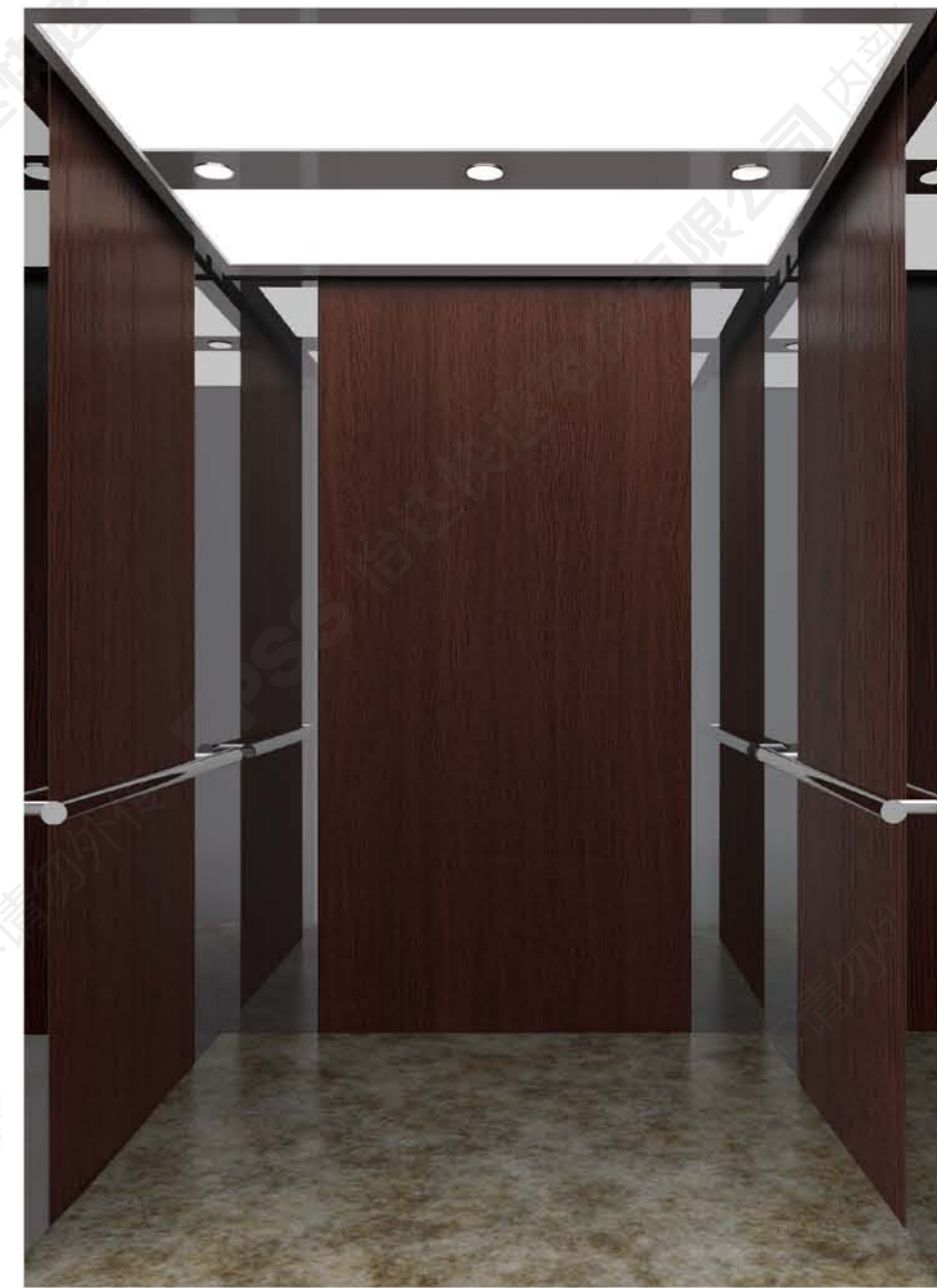

后视角



后视角

EX-W06 轿厢 (选配)

吊顶: EX-J110A 铝合金框架(钛黑)+亚克力+LED灯
 操纵箱: EX-AC97A 一体式操纵箱
 显示: 段码LED
 后壁: 黑钛镜面不锈钢面+艺术装饰板
 侧壁: 黑钛镜面不锈钢面+钛金蚀刻不锈钢面
 地坪: EX-DM68 大理石拼花
 轿门: 钛金喷砂不锈钢面
 前壁: 黑钛镜面不锈钢面

EX-W06 Cabin (Optional)

Ceiling: EX-J110A Aluminium alloy fram
(Ti-plated Black), acrylic, LED lighting
 C.O.P.: EX-AC97A Integral C.O.P.
 Indicator: LED display
 Rear wall: Ti-plated mirror stainless steel (Black),
art decorative plate
 Side wall: Ti-plated mirror stainless steel (Black),
Ti-plated etched stainless steel (Gold)
 Flooring: EX-DM68 Marble Splice
 Cabin door: Ti-plated sandblasted stainless steel (Gold)
 Front wall: Ti-plated mirror stainless steel (Black)

EX-W07 轿厢 (选配)

吊顶: EX-J115A 香槟金镜面不锈钢+亚克力+LED灯
 操纵箱: EX-AC97A 一体式操纵箱
 显示: 段码LED
 后壁: 香槟金镜面不锈钢面+木饰面
 侧壁: 香槟金镜面不锈钢面+木饰面
 扶手: EX-FS05A原木, 香槟金不锈钢管哑光短纹
 地坪: EX-DM69 (大理石拼花)
 轿门: 香槟金喷砂不锈钢面
 前壁: 香槟金喷砂不锈钢面

EX-W07 Cabin (Optional)

Ceiling: EX-J115A Mirror stainless steel (Champagne
gold), acrylic image plate, LED lighting
 C.O.P.: EX-AC97A Integral C.O.P.
 Indicator: LED display
 Rear wall: Mirror stainless steel (Champagne gold), wood
vener
 Side wall: Mirror stainless steel (Champagne gold), wood
vener
 Handrail: EX-FS05A wood, matt stainless pipe (Champagne gold)
 Flooring: EX-DM69 Marble Splice
 Cabin door: Sandblasted stainless steel (Champagne gold)
 Front wall: Sandblasted stainless steel (Champagne gold)

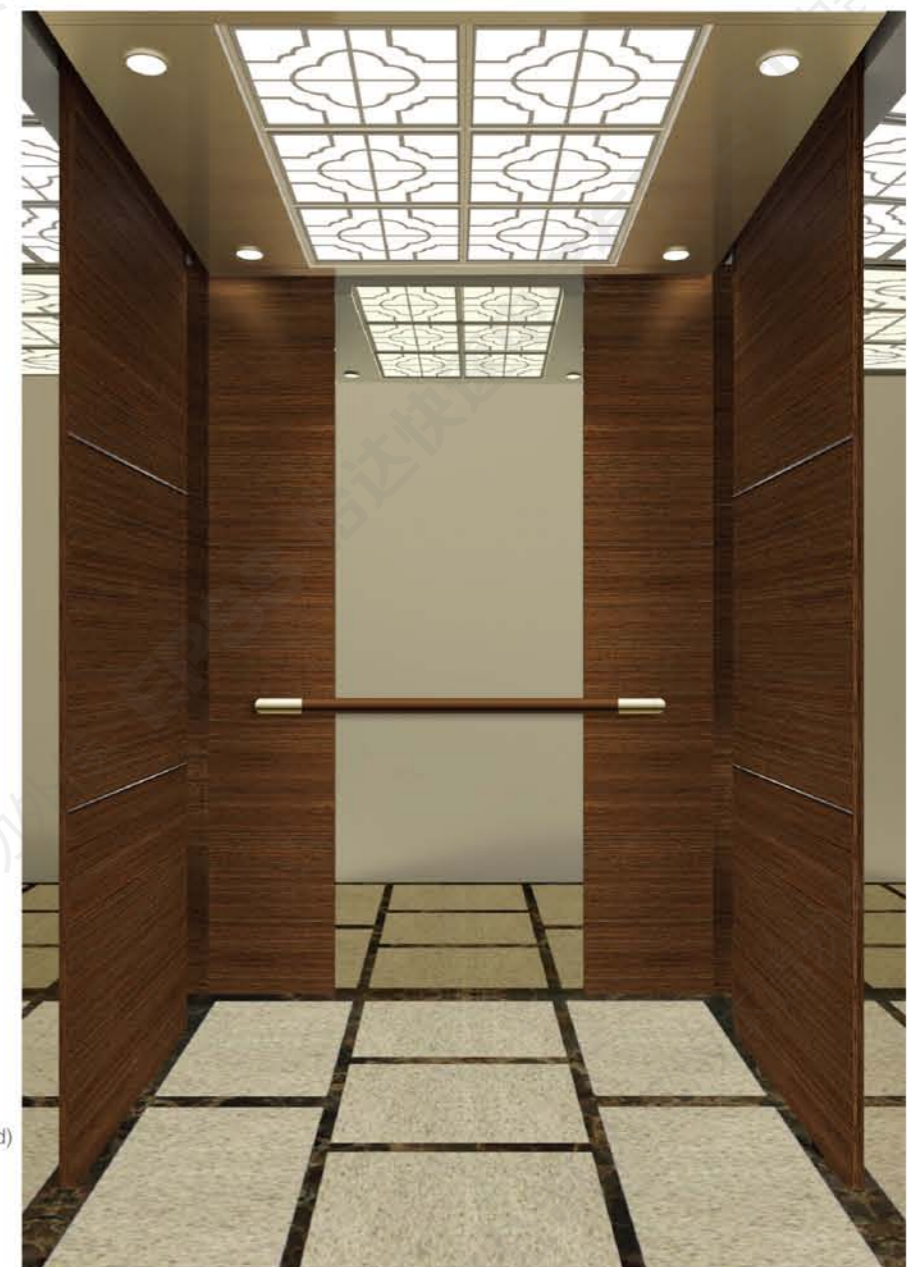

后视角



EX-M01 (标配)

小门套
Narrow jamb
(standard)

厅门: 发纹不锈钢面
门套: 发纹不锈钢面

Landing door: Hairline stainless steel
Jamb: Hairline stainless steel



EX-M16 (选配)

小门套
Narrow jamb
(optional)

厅门: 镜面蚀刻不锈钢面
门套: 镜面不锈钢面

Landing door: Mirror etched stainless steel
Jamb: Mirror stainless steel

专利号(Patent NO.): 201530303082.2



EX-M23 (选配)

大门套
Wide jamb
(optional)

厅门: 发纹蚀刻不锈钢面
门套: 发纹不锈钢面

Landing door: Hairline etched stainless steel
Jamb: Hairline stainless steel

专利号(Patent NO.): 201530303059.3



EX-M19 (选配)

带门楣大门套
Wide jamb with transom
(optional)

厅门: 钛金发纹蚀刻不锈钢面
门套: 钛金不锈钢面

Landing door: Ti-plated hairline etched stainless steel
Jamb: Ti-plated stainless steel

专利号(Patent NO.): 201530301452.9



Landing door
(optional)

厅门 (选配)

更多选配请联系我们……
Please contact us for more options

C.O.P./L.O.P. 操纵箱 / 呼梯盒

半高式操纵箱
Half height C.O.P.



EX-AC96A
段码LED
LED display
(标配 standard)

EX-AC96B
段码LED
LED display
(标配 standard)

楼层显示器
Floor indicator



EX-HX96
段码LED
LED display
(选配 optional)

壁挂式外呼
Wall mounted L.O.P.

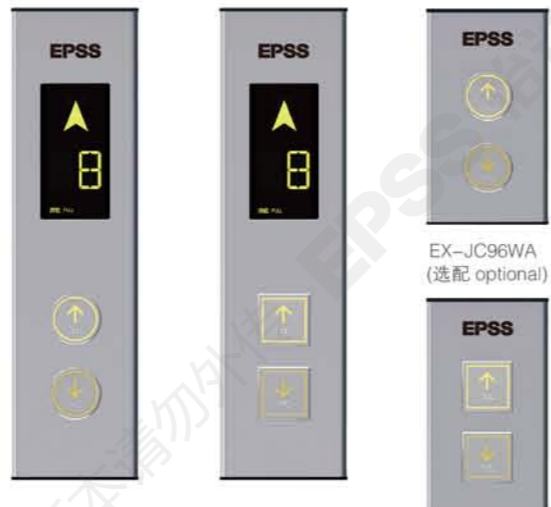

EX-JC96A
段码LED
LED display
(标配 standard)

EX-JC96B
段码LED
LED display
(标配 standard)

EX-JC96WB
(选配 optional)
与楼层显示器配套使用
Using with floor indicator



EX-BC492A
残疾人操纵箱
Handicapped C.O.P.
(选配 optional)

显示和按钮发光色可选: 黄色、白色
Optional indicator & button light color: yellow, white

此系列专利号(Patent NO.):201630636751.2

一体式操纵箱
Integral C.O.P.
EX-AC97A
段码LED
LED display
(选配 optional)



操纵箱显示配真彩液晶 (选配)
C.O.P. Colorful LCD display (optional)



操纵箱显示配多媒体 (选配)
C.O.P. Multimedia display (optional)



外呼显示
真彩液晶 (选配)
L.O.P. TFT display
(optional)



外呼显示
段码液晶 (选配)
L.O.P. LCD display
(optional)

OCB按钮(OCB button)



OCB-96A

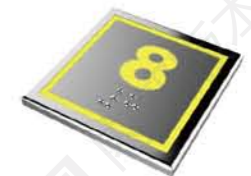

OCB-96B



天空系列安全吊顶

此系列吊顶配合EKW50/EKW55无机房乘客电梯设计,造型简洁纤薄,设计理念来自天空,模仿自然光照柔和的光照,光线均匀柔和自然,照度舒适宜人。

The sky series safety ceiling

This series of ceiling with EKW50 / EKW55 design which have simple and slim shape. Its design conceives from the sky. It mimics the natural soft light, making the illumination comfortable and pleasant.

Ceiling (optional) 吊顶 (选配)

EX-J111

铝合金框架+亚克力+LED灯
Aluminium alloy fram,acrylic,LED lighting



EX-J112

铝合金框架+镜面不锈钢+亚克力+LED灯
Aluminium alloy fram,Mirror stainless steel, acrylic,LED lighting



EX-J113

镜面不锈钢框架+亚克力+LED灯
Mirror stainless steel frame,acrylic, LED lighting



EX-J115

镜面不锈钢框架+亚克力+LED灯
Mirror stainless steel frame,acrylic, LED lighting

此型号更多图案设计请联系我们……
Please contact us for more picture of EX-J115

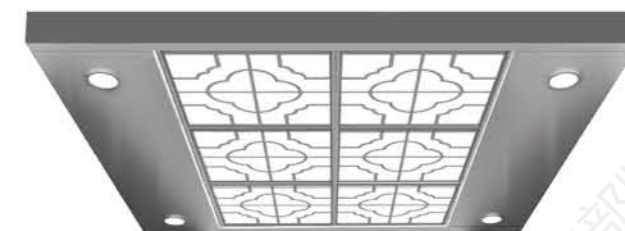

Ceiling (standard) 吊顶 (标配)

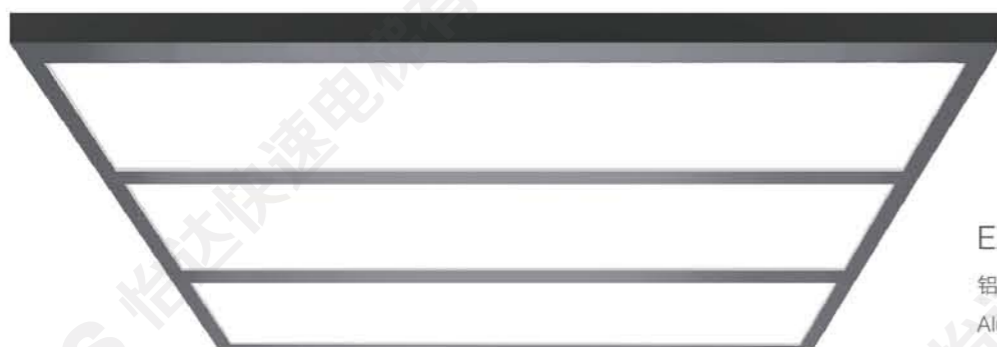

EX-J110

铝合金框架+亚克力+LED灯
Aluminium alloy fram,acrylic,LED lighting

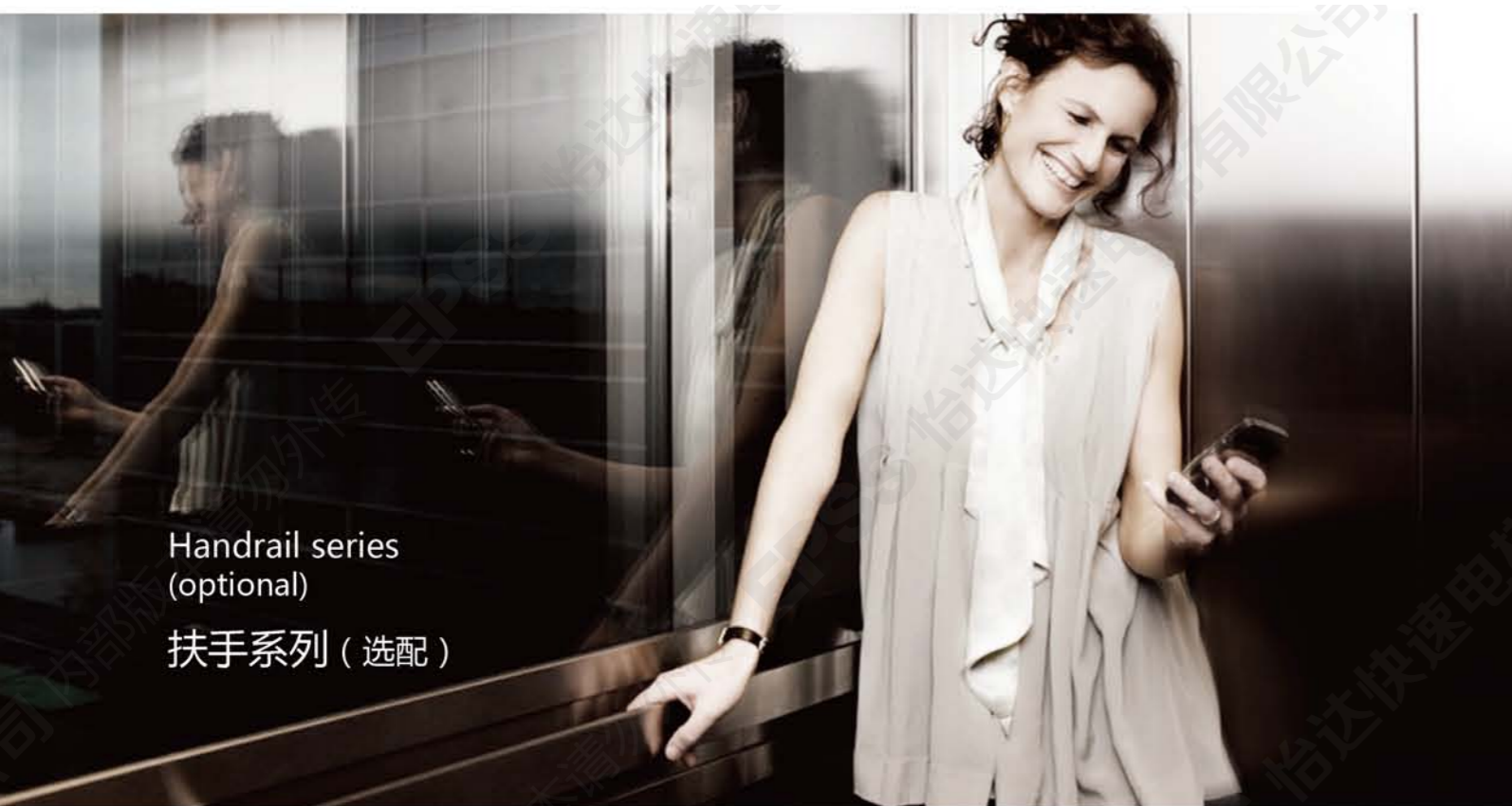

Handrail series
(optional)
扶手系列 (选配)

EX-FS01
不锈钢管亚光短纹
Matt stainless pipe



EX-FS05
原木, 不锈钢亚光短纹
Wood, matt stainless pipe



EX-FS03
不锈钢短纹圆弧头
Stainless steel with arc angel



EX-FS16
拉丝不锈钢
Brushed stainless steel



Floor series 地板系列

石塑地板
(标准可选款式)
Vinyl tile
(Standard optional)



EX-DB101



EX-DB102



EX-DB103



EX-DB110

PVC拼花地板
(选配)
PVC Splice
(Optional)



EX-DB03



EX-DB04



EX-DB16



EX-DB108

拼花大理石地坪
(选配)
Marble Splice
(Optional)

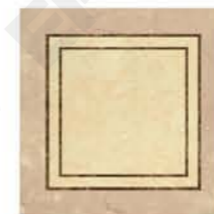

EX-DM13



EX-DM69



EX-DM71



EX-DM72

Laminated metal 彩纹钢板



B125黑檀木
Black wood



B107深柚木
Dark teak wood



B103红木
Red wood

Sprayed S. S. colors 喷塑色标



EX-YS07



EX-YS08



EX-YS09

+ EKW50土建参数 Civil Engineering Parameters

井道立面布置图
Shaft elevation plan view

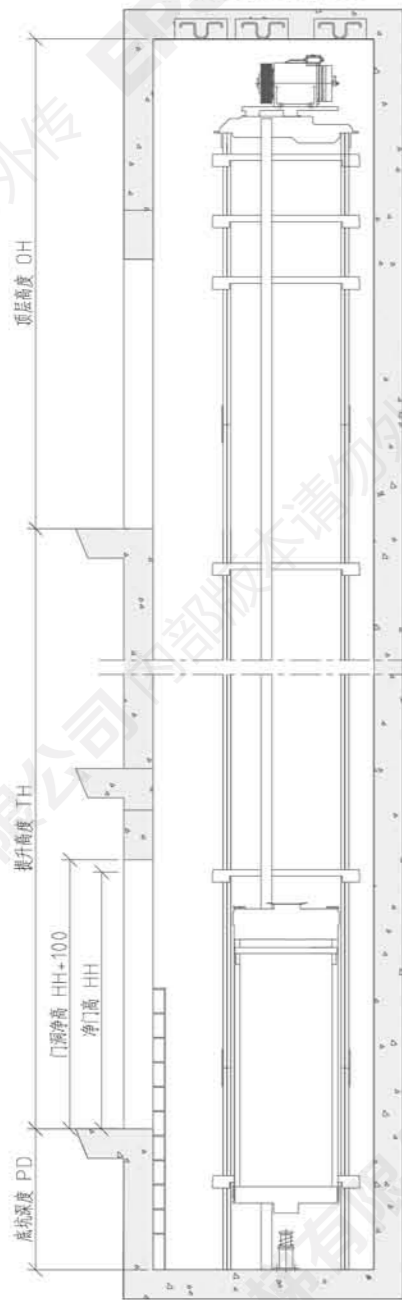

速度 Speed(m/s)	顶层高度 OH(mm)	底坑深度 PD(mm)	最大行程 Max travel(m)
1.0	3850	1150	60
1.5	4000	1250	90
1.75	4050	1300	105
2.0	4150	1350	120

- 注1: 本梯形标准轿厢内高(不含吊顶)为2400mm;
 - 注2: 本图为对重左置, 对重右置时土建需对称设计;
 - 注3: 当用户实际井道尺寸、顶层高度及底坑深度小于以上尺寸时, 需采用非标设计, 请与本公司联系;
 - 注4: 当用户电梯底坑下有过人的空间, 需增加对重安全钳, 请与本公司联系;
 - 注5: 井道壁混凝土墙应坚固, 其耐压强度应不低于30Mpa, 混凝土墙厚不小于150mm.
- Remark1: For this lift model, the standard cabin internal height (without ceiling) is 2400mm;
Remark2: This diagram is designed for counterweight left, symmetrical design is necessary for counterweight right
Remark3: When the actual shaft size, overhead height and pit depth is less than the above size, need adopt non-standard design, please contact with our company;
Remark4: When there is excessive space under the pit, counterweight safety gear should be added, please contact with our company;
Remark5: Shaft concrete wall should be strong, the pressure strength should not be less than 30Mpa, concrete Wall thickness should not less than 150mm.

井道平面布置图 (中分门)
Shaft plan view (center opening)

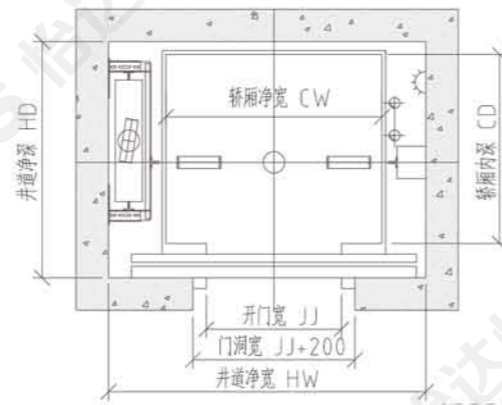

井道平面布置图 (中分门偏轿厢中心)
Shaft plan view (offset center opening)

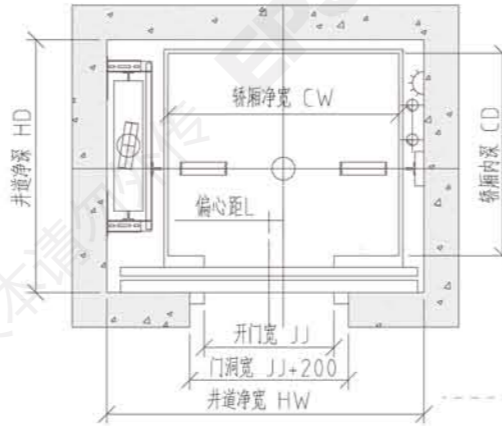

井道平面布置图 (旁开门)
Shaft plan view (two panel side opening)

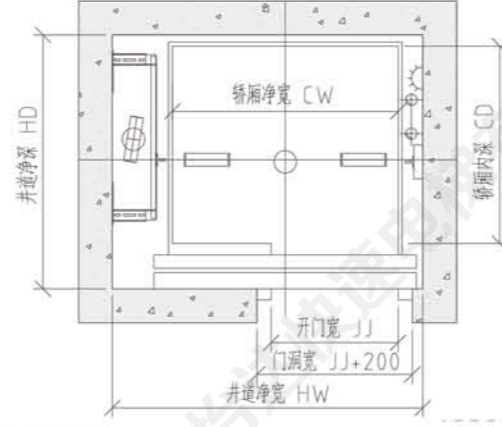

土建参数表 (中分门) Civil Engineering Parameters (center opening)

载重量 Capacity kg	载客人数 No. of persons	速度 Speed(m/s)	轿厢类型 Car type	开门方式 Door open type	净开门 (宽x高) Entrance(JJ x HH)mm	轿厢净尺寸 Car net size 宽x深 CW x CD(mm)	井道净尺寸(mm) Shaft inside dimension 宽x深 HW x HD(mm)
450	6	≤2.0	标准型 standard	中分门	800 x 2100	1100 x 1100	1800 x 1450
630	8	≤2.0	标准型 standard	中分门	800 x 2100	1100 x 1400	1800 x 1750
800/825	10/11	≤2.0	标准型 standard	中分门	800 x 2100	1350 x 1400	1950 x 1750
			深轿厢 deep car	中分门	800 x 2100	1000 x 1950	1800 x 2300
900	12	≤2.0	标准型 standard	中分门	900 x 2100	1500 x 1400	2100 x 1750
			深轿厢 deep car	中分门	900 x 2100	1100 x 1950	2000 x 2300
1000/1050	13/14	≤2.0	标准型 standard	中分门	900 x 2100	1600 x 1400	2150 x 1750
			深轿厢 deep car	中分门	900 x 2100	1400 x 1600	2050 x 1950
1150	15	≤2.0	标准型 standard	中分门	1000 x 2100	1600 x 1650	2400 x 2000
1250	16	≤2.0		中分门	1000 x 2100	1500 x 1900	2350 x 2250
1350	18	≤2.0		中分门	1000 x 2100	1600 x 1900	2400 x 2250
1600	21	≤2.0		中分门	1100 x 2100	1700 x 2000	2550 x 2350
1800	24	≤2.0		中分门	1100 x 2100	1800 x 2100	2600 x 2450
2000	26	≤2.0		中分门	1200 x 2100	1900 x 2100	2750 x 2450

土建参数表 (中分门偏轿厢中心) Civil Engineering Parameters (offset center opening)

载重量 Capacity kg	载客人数 No. of persons	速度 Speed(m/s)	开门偏心距 Offset door open (L)mm	开门方式 Door open type	净开门 (宽x高) Entrance(JJ x HH)mm	轿厢净尺寸 Car net size 宽x深 CW x CD(mm)	井道净尺寸(mm) Shaft inside dimension 宽x深 HW x HD(mm)
450	6	≤2.0	100	中分门	★750 x 2100	1100 x 1100	1650 x 1450
630	8	≤2.0	100	中分门	★750 x 2100	1100 x 1400	1650 x 1750
800/825	10/11	≤2.0	25	中分门	800 x 2100	1350 x 1400	1900 x 1750
900	12	≤2.0	50	中分门	900 x 2100	1500 x 1400	2050 x 1750
1000/1050	13/14	≤2.0	100	中分门	900 x 2100	1400 x 1600	1950 x 1950
1150	15	≤2.0	100	中分门	1000 x 2100	1600 x 1650	2300 x 2000
1250	16	≤2.0	125	中分门	1000 x 2100	1500 x 1900	2200 x 2250
1350	18	≤2.0	100	中分门	1000 x 2100	1600 x 1900	2300 x 2250
1600	21	≤2.0	150	中分门	1100 x 2100	1700 x 2000	2400 x 2350
1800	24	≤2.0	100	中分门	1100 x 2100	1800 x 2100	2500 x 2450
2000	26	≤2.0	150	中分门	1200 x 2100	1900 x 2100	2600 x 2450

土建参数表 (旁开门) Civil Engineering Parameters (two panel side opening)

载重量 Capacity kg	载客人数 No. of persons	速度 Speed(m/s)	轿厢类型 Car type	开门方式 Door open type	净开门 (宽x高) Entrance(JJ x HH)mm	轿厢净尺寸 Car net size 宽x深 CW x CD(mm)	井道净尺寸(mm) Shaft inside dimension 宽x深 HW x HD(mm)
450	6	≤2.0	标准型 standard	旁开门	800 x 2100	1100 x 1100	1650 x 1500
630	8	≤2.0	标准型 standard	旁开门	800 x 2100	1100 x 1400	1650 x 1800
800/825	10/11	≤2.0	标准型 standard	旁开门	800 x 2100	1350 x 1400	1900 x 1800
			深轿厢 deep car	旁开门	800 x 2100	1000 x 1950	1550 x 2350
900	12	≤2.0	标准型 standard	旁开门	900 x 2100	1500 x 1400	2050 x 1800
			深轿厢 deep car	旁开门	900 x 2100	1100 x 1950	1650 x 2350
1000/1050	13/14	≤2.0	标准型 standard	旁开门	900 x 2100	1600 x 1400	2150 x 1800
			深轿厢 deep car	旁开门	900 x 2100	1400 x 1600	1950 x 2000
1150	15	≤2.0	标准型 standard	旁开门	1200 x 2100	1600 x 1650	2300 x 2050
1250	16	≤2.0		旁开门	1200 x 2100	1500 x 1900	2200 x 2300
1350	18	≤2.0		旁开门	1200 x 2100	1600 x 1900	2300 x 2300
1600	21	≤2.0		旁开门	1300 x 2100	1700 x 2000	2400 x 2400
1800	24	≤2.0		旁开门	1400 x 2100	1800 x 2100	2500 x 2500
2000	26	≤2.0		旁开门	1400 x 2100	1900 x 2100	2600 x 2500

+ EKW55土建参数 Civil Engineering Parameters

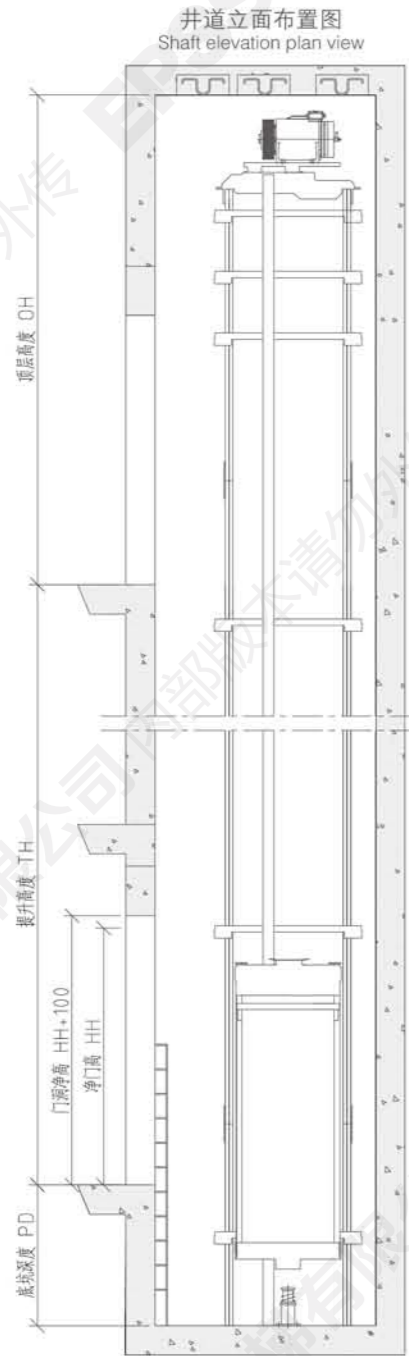

速度 Speed(m/s)	顶层高度 OH(mm)	底坑深度 PD(mm)	最大行程 Max travel(m)
1.0	3850	1300	60
1.5	4100	1400	90
1.75	4150	1450	105
2.0	4250	1700	120

注1: 本梯形标准轿厢内高(不含吊顶)为2400mm;
 注2: 本图为对重左置, 对重右置时土建需对称设计;
 注3: 当用户实际井道尺寸、顶层高度及底坑深度小于以上尺寸时, 需采用非标设计, 请与本公司联系;
 注4: 当用户电梯底坑下有过的空间, 需增加对重安全钳, 请与本公司联系;
 注5: 井道壁混凝土墙应坚固, 其耐压强度应不低于30Mpa, 混凝土墙厚不小于150mm.
 Remark1: For this lift model, the standard cabin internal height (without ceiling) is 2400mm;
 Remark2: This diagram is designed for counterweight left, symmetrical design is necessary for counterweight right.
 Remark3: When the actual shaft size, overhead height and pit depth is less than the above size, need adopt non-standard design, please contact with our company;
 Remark4: When there is excessive space under the pit, counterweight safety gear should be added, please contact with our company;
 Remark5: Shaft concrete wall should be strong, the pressure strength should not be less than 30Mpa, concrete Wall thickness should not less than 150mm.

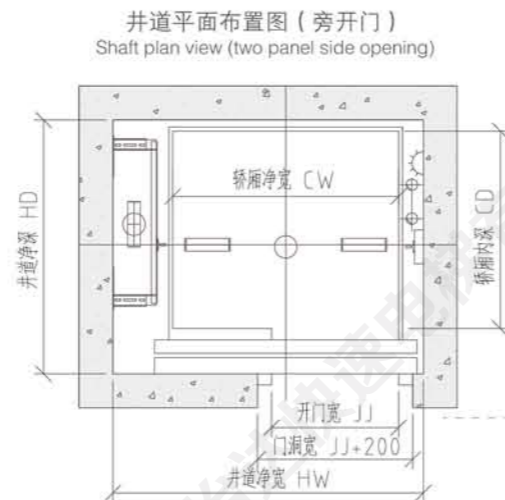
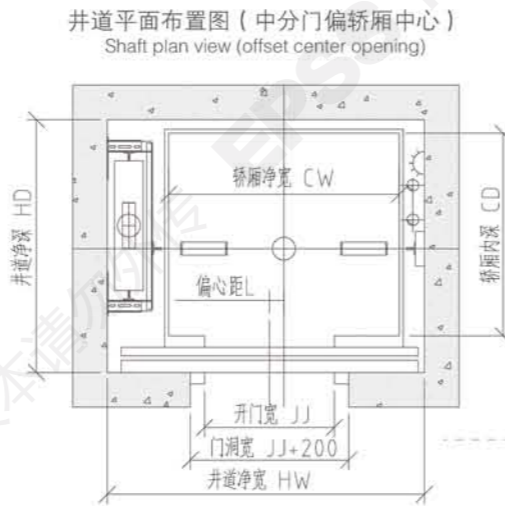
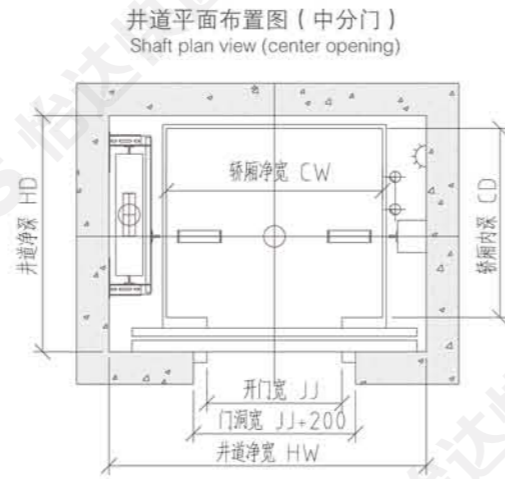

土建参数表(中分门) Civil Engineering Parameters (center opening)

载重量 Capacity kg	载客人数 No. of persons	速度 Speed(m/s)	轿厢类型 Car type	开门方式 Door open type	净开门(宽x高) Entrance(JJ x HH)mm	轿厢净尺寸 Car net size 宽x深 CW x CD(mm)	井道净尺寸(mm) Shaft inside dimension 宽x深 HW x HD(mm)
450	6	≤2.0	标准型 standard	中分门	800 x 2100	1100 x 1100	1850 x 1450
630	8	≤2.0	标准型 standard	中分门	800 x 2100	1100 x 1400	1850 x 1750
800/825	10/11	≤2.0	标准型 standard	中分门	800 x 2100	1350 x 1400	2000 x 1750
			深轿厢 deep car	中分门	800 x 2100	1000 x 1950	1800 x 2300
900	12	≤2.0	标准型 standard	中分门	900 x 2100	1500 x 1400	2150 x 1750
			深轿厢 deep car	中分门	900 x 2100	1100 x 1950	2000 x 2300
1000/1050	13/14	≤2.0	标准型 standard	中分门	900 x 2100	1600 x 1400	2200 x 1750
				中分门	900 x 2100	1400 x 1600	2100 x 1950
				中分门	900 x 2100	1100 x 2100	2000 x 2450

土建参数表(中分门偏轿厢中心) Civil Engineering Parameters (offset center opening)

载重量 Capacity kg	载客人数 No. of persons	速度 Speed(m/s)	开门偏心距 Offset door open (L)mm	开门方式 Door open type	净开门(宽x高) Entrance(JJ x HH)mm	轿厢净尺寸 Car net size 宽x深 CW x CD(mm)	井道净尺寸(mm) Shaft inside dimension 宽x深 HW x HD(mm)
450	6	≤2.0	100	中分门	★750 x 2100	1100 x 1100	1700 x 1450
630	8	≤2.0	100	中分门	★750 x 2100	1100 x 1400	1700 x 1750
800/825	10/11	≤2.0	25	中分门	800 x 2100	1350 x 1400	1950 x 1750
900	12	≤2.0	50	中分门	900 x 2100	1500 x 1400	2100 x 1750
1000/1050	13/14	≤2.0	100	中分门	900 x 2100	1400 x 1600	2000 x 1950

土建参数表(旁开门) Civil Engineering Parameters (two panel side opening)

载重量 Capacity kg	载客人数 No. of persons	速度 Speed(m/s)	轿厢类型 Car type	开门方式 Door open type	净开门(宽x高) Entrance(JJ x HH)mm	轿厢净尺寸 Car net size 宽x深 CW x CD(mm)	井道净尺寸(mm) Shaft inside dimension 宽x深 HW x HD(mm)
450	6	≤2.0	标准型 standard	旁开门	800 x 2100	1100 x 1100	1700 x 1500
630	8	≤2.0	标准型 standard	旁开门	800 x 2100	1100 x 1400	1700 x 1800
800/825	10/11	≤2.0	标准型 standard	旁开门	800 x 2100	1350 x 1400	1950 x 1800
			深轿厢 deep car	旁开门	800 x 2100	1000 x 1950	1600 x 2350
900	12	≤2.0	标准型 standard	旁开门	900 x 2100	1500 x 1400	2100 x 1800
			深轿厢 deep car	旁开门	900 x 2100	1100 x 1950	1700 x 2350
1000/1050	13/14	≤2.0	标准型 standard	旁开门	900 x 2100	1600 x 1400	2200 x 1800
				旁开门	900 x 2100	1400 x 1600	2000 x 2000
				旁开门	900 x 2100	1100 x 2100	1700 x 2500

+ 标配功能 Standard Function

运行功能	
电梯变频驱动	精确调整电动机转速,令电梯启动、运行、停止时的速度曲线平稳、圆滑,获得良好的舒适感。
门机变频驱动	精确调整门电机转速,使电梯门的开启、关闭更轻柔灵敏。
自动运行	电梯在无人操控的情况下,按照乘客给出的指令自动运行,将乘客送至目的层。
司机运行	电梯由司机进行操控,司机按乘客的要求给出指令,电梯按指令要求驶向目的层。
最佳曲线自动生成	以距离为原则,自动运算出最适合人机功能原理的速度曲线,没有个数的限制,而且不受短楼层的限制。
加速段载车响应	系统允许在电梯加速的过程中载车,自动响应相应的服务楼层指令,提高运行效率。
分时服务层选择	系统可以灵活设定分时服务时间段和相应的分时服务楼层。
满载直驶	当轿内满载时,为保持最大运行效率,该轿厢将自动越过召唤层站。
开门时间自动调整	按照层站召唤或轿厢召唤的区别,自动调整保持开门时间。
本层重开门	关门途中,可以按本层站召唤按钮使门重新开启。
即时关门	电梯停站开门到位时,按下关门按钮,门立即被关闭。
停梯开门	电梯减速平层,直到完全停稳后方可开门。
轿厢到站钟	装于轿顶的电子钟的钟声告知乘客电梯已到站。
指令误登记消除	乘客可以采用连续按动指令按钮两次的方法来取消错误登记的指令。
驻停	关闭电锁后电梯进入驻停状态,电梯不再响应任何外呼。
换站停靠	如果电梯在开门超过开门保护时间后,开门到位信号仍然无效,电梯将自动关门,自动运行至下一层停靠。
低速自救	当电梯处于非检修状态,且未停在平层区,此时如符合运行的安全要求,电梯将自动以慢速运行至平层区,然后开门。
启动转矩自动补偿	电梯在运行前,自动根据轿厢的载重情况,进行启动补偿,达到平稳启动的效果,提高乘坐舒适感。
直接停靠	自动运算生成运行曲线,没有爬行,直接停靠平层位置,提高运行效率。
按钮嵌入自诊断	若某层呼梯按钮嵌入持续未断开,系统不再登记该层呼梯。
防捣乱	当电梯连续多次到站开门光幕不动作,系统判断为捣乱,取消已经登记的指令。
空闲返基站	自动状态下,在设定的时间范围内电梯未使用,电梯自动返回基站等候乘客。
消防返回	消防状态下,所有召唤均被取消,电梯立即驶往指定救援层站停靠,并自动开门。

Running function

VVVF Drive	Motor rotating speed can be precisely adjusted to get smooth speed curve in elevator start, travel and stop and gain the comfort.
VVVF Door Operator	Motor rotating speed can be precisely adjusted to get the more gentle and sensitive door machine start/stop.
Automatic Running	When there is no attendant who operates elevator, elevator will run to the destination floor according to the instruction of passenger automatically.
Attendant Running	Elevator is operated by attendant, attendant press car calls as request of passengers and elevator will run to the destination floor according to the car calls.
VIP (special) Running	Elevator has priority to run to VIP destination floor to provide VIP service.
Best Curve Autogeneration	Based on principle of distance, calculating the speed curve, which is most suitable for human-machine function theory, and without limit by floor number and short floor height.
Response in Accelerating Process	System allows the elevator to stop during accelerating process, to respond service floor call. This function improves the running efficiency.
Time-sharing Service Floor Selection	System allows to set time period and corresponding service floor flexibly.
Full Load by Pass	When the car is full load, the elevator will by pass the landing calls which has been registered to keep maximum running efficiency.
Automatic Adjustment of Door Open Holding Time	According to current registered landing call and call situation, system will automatically adjust the door open holding time.
Door Re-open at Current Floor	When door is closing, door can be re-opened by pushing landing call button at current floor.

Instant Door Close	When door is completely opened, by pushing the door close button, door will close at once.
Door Open After Stop	Elevator decelerates to land, until it completely stops, then open the door.
Arrival Gong	Arrival gong on the car top advices passengers that elevator arrives.
Car Call Cancel	If passengers press a wrong floor button in car, to press same button again can cancel the wrong register.
Parking	When electric key switch is turn off, elevator enters into parking state, it will not serve to any landing call.
Next Landing	If door open limit signal is invalid when door open time exceeds the preset door open protection time, the elevator will close the door automatically and run to the next landing for parking.
Self Rescue in Low Speed	When the elevator is not in inspection status and leveling position, elevator will run slowly to the leveling zone and open the door if it meets safety running requirement at the time.
Starting Torque Automatic	Controller gives a starting compensation to reach smooth starting and enhance comfortable feeling according to the car load before elevator running.
Direct Landing	Running curve is generated automatically without crawling process. Elevator lands at the leveling zone directly, which enhances the running efficiency greatly.
Button Inset Diagnose	If any floor button is continually being pressed, system won't register this floor call.
Anti-nuisance	When light curtain doesn't act continuously on several landings, system will judge it as nuisance, all the registered car calls will be cancelled.
Return to G floor in Free	In automatic status, if elevator is not used for a setting period, the elevator will return to G floor to wait passengers automatically.
Fire Emergency Return	In fire emergency state, all landing calls are eliminated, elevator runs to the preset floor and open door.

应急功能

应急照明	停电时,自动打开轿内应急照明。
紧急电动运行	当进入紧急电动状态时,轿厢以低速点动运行。
五方通话装置	通过对讲机,可在轿内、轿顶、电梯机房、井道底坑、救援值班室之间通话。
警铃	紧急时,连续按下轿内操纵箱上的警铃按钮,安装于轿厢顶上的警铃会鸣响。

Emergency Function

Emergency Lighting	When power is off, car emergency light gets on automatically.
Emergency Electric Operation	When elevator enters into emergency electric operation state, elevator runs in low speed jog running.
5-way intercom	Communication between car inner, car top, machine room, pit and security room through intercoms is realized
Alarm Bell	In emergency situation, pressing the alarm bell button on C.O.P. continuously, alarm bell on car top will ring.

节能功能

风扇、照明自动关闭	在规定的时间内没有召唤或指令信号,轿厢内风扇和照明会自动关闭,节约能源。
定时自动开关梯	系统按所设置时间自动开梯/关梯。
夜间到站钟取消功能	在设定的时间范围内,电梯将取消到站钟功能。

Energy saving

Fan&Light Automatic Off	If there is no car call or landing call in a preset time, car inner fan and light will be automatically off to save energy.
Start/Stop Timing	System starts / stops elevator running according to the preset timing.
Nighttime Arrival Gong	Arrival gong function will be cancelled within the setting time.
Canelling Function	

+ 标配功能 Standard Function

安全功能	
抱闸力自动检测	系统将定期对制动器的制动力进行检测,如制动力不符合要求,采取保护措施。
光幕保护	光幕被遮挡时,关门动作立即停止且自动开门。
超载停驶	轿厢超载时,电梯门常开,蜂鸣器鸣响并停止于该层站。
曳引绳滑动检测	实时检测电梯运行位置偏移量,钢丝绳打滑超出允许值时,电梯减速,停止运行。
检修操作	当进入检修状态时,轿厢以低速点动运行。
故障自诊断	系统自动获取故障发生时的状态信息,以便快速排除故障,迅速恢复电梯运行。
故障自动停靠	运行中系统发生故障,满足安全运行要求的前提下,电梯就近层开门。
重复开关门	电梯开关门时因阻碍或干扰,电梯门会重复打开或关闭。
上下越层及上下极限保护装置	该装置可有效地防止当电梯万一发生失控时的冲顶或撞底现象,使电梯更安全可靠。
下行超速保护装置	当电梯下降运行超速时,该装置自动切断控制电源,使电机停止运转,安全钳动作,强制电梯停止运行。
上行超速保护装置	当电梯上行超速时,该装置自动将电梯减速或制停。
安全回路保护	安全回路断开或安全回路接触器粘连,电梯立即停止。
门连锁保护	门全部关闭,电梯方可运行,或门锁接触器粘连,电梯立即停止。
接触器保护	系统随时检测接触器动作是否可靠,发现异常,立即停止运行。
抱闸检测保护	对抱闸的打开和闭合实时检测,若发生异常,或抱闸接触器粘连,电梯禁止启动。
保安层功能	启用功能后,电梯在规定的时段内,电梯每次会先运行到保安层开门,然后再运行到目的层,提高安全性。
电压自动识别功能	系统通过检查输入电压的大小,自动调节电梯运行速度,以适应电源功率不足的情况(如应急运行)。
轿厢意外移动保护功能	在开锁区域且轿门未关闭的情况下,由于相关元件失效引起轿厢离开层站,保护装置将立即动作,停止轿厢移动。
电梯防松绳保护装置	当电梯任意一根钢丝绳张力变小或断开,该装置立即动作,使电梯停止运行。

Safety Functin

Brakeage Automatic Detection	The brakeage will be detected by system automatically and regularly. If brakeage does not meet the requirement, it should take protection measures.
Light Curtain Protection	When light curtain is sheltered, door will stop closing at once and automatically open.
Overload Stop	When elevator is overload, elevator door keeps opening, buzz rings and elevator stops at the current floor.
Hoisting Rope Sliding Detection	Deviation of running location should be detected in real time. Elevator slow down and stop running when the steel rope slipping exceeds the allowable value.
Inspection Operation	When elevator enters into inspection state, car runs in jog state.
Troubleshooting	Controller can acquire status information automatically when fault occurs to facilitate the fault elimination and restore elevator running.
Auto-landing with Fault	When there is any fault occurred in elevator running, and safety requirements for elevator running are being met,the car lands to the nearest floor.
Door Close Repeat	Due to the obstacle or interference, elevator door repeats door open and close.
Top/bottom Limit and Final Limit Protection	The devices can prevent elevator from crashing to the top or bottom of hoistway in case that elevator is out of control with fault. It ensures the safety and reliability.
Down Running Protection	When elevator runs down in over speed, this device cuts off the control power to stop the motor running. safety gear is motivated to force elevator to stop.
Up Running Protection	When elevator runs up in over speed, the device forces elevator to decelerate and braking.
Safety Circuit Protection	When elevator circuit is open or contacts are adhered, elevator stops running at once.
Door Interlock Protection	Only when all doors are completely closed, elevator can run. When door interlock contacts are adhered, elevator stops running at once.
Main Contactor Protection	System detects if the main contactor acts reliably, if any abnormal is detected, elevator stops running at once.
Brake Detecting Protection	System detects the brake state, if there is any abnormal or braking contacts are adhered, elevator can't start running.
Security Floor Function	Once this function is applied, elevator will run to security floor and open the door before running to the destination floor every time to improve safety.
Voltage Automatic Recognition Function	System will adjust running speed automatically in order to adapt to underpower condition(such as emergency running) by checking input voltage.

Unexpected car movement protection (UCMP)	At unlocking zone with the car door opened,if the car leaves the landing floor due to invalidation of relative component,the protection device will act immediately to stop the car.
Rope anti loose protection device	When tension of any elevator rope becomes smaller or disconnected, the device acts immediately so that the elevator stops running.

人机界面

微动指令按钮	轿内操纵箱指令按钮及层站召唤按钮采用新型微动按钮。
运行状态显示	系统能显示电梯运行方向、层楼、开关门、故障等信息。
机房选层	通过控制柜内的按键操作,进行内选登记。
不停层任意设定	可根据用户需要任意设定不停靠层站。
待梯层任意设定	可根据用户需要任意设定待梯层站。
层楼显示设定	可根据用户需要设置各楼层的显示字符(字母、数字)。
井道参数自学	通过自学,系统将测出各层楼的间距数据,并自动保存。
干扰评价	对通讯信号传输进行干扰评价,反应当前干扰程度。
运行次数及时间记录	系统可自动记录电梯运行次数及时间。

Human-Machine Interface

Micro Push Button	C.O.P. and H.O.P. both adopts new micro push button.
Running State Display	System can indicates running direction, floor, door state, default ,ect.
Floor Selection in Machine Room	By button operation in the control cabinet, car call can be registered.
No Stop Floor Set	Set the non-stop floor according to the customer' requirement.
Homing Floor Set	Set the homing floor according to the customer' requirement.
Floor Indication Set	Set the indication (word or digit) according to customer need for every floor.
Hoistway Self-learning	Through hoistway self-learning, system can measure out the distance between every floor and record them automatically.
Interference Evaluation	System can evaluate the interference of communication signal transmission and reflect the current degree of interference.
COP Debugging	Debugging personnel do the elevator debugging through interface connection system and it improves debugging efficiency.
Running Times and Time Record	System can automatically record the times and period of running.

+ 选配功能 Optional Function

监控功能

远程监控	通过有线或无线通讯模块和软件,对电梯运行状态进行实时监控。
曳引机监控	无机房电梯装有曳引机监控装置,维修人员无需进入井道就可查看曳引机运行状况及轿厢位置。

Monitor Function

Remote Monitor	By wire or wireless communication module, system performs real-time monitoring of elevator running state.
Traction Machine Monitor	The traction machine monitor is installed in the machine room less elevator. The maintenance personnel can check the running state of traction machine and car position without entering into hoistway.

+ 选配功能 Optional Function

运行功能	
消防联动功能	系统接收到大楼消防信号，电梯进入消防状态，返回到消防层后反馈信号给大楼消防中心。
提前开门	电梯减速进入开门区域，提前开门，提高运行效率。
贯通门独立控制	当轿厢有两个门时，可根据用户的具体需求实现对两个门的独立控制。
再平层功能	电梯在当前层，当过多乘客进入电梯或离开电梯时，由于钢丝绳的伸长或缩短，轿厢偏离平层区，电梯将启动低速运行至平层区。
并联功能	用于两台电梯并联运行，互相调度减少乘客的候梯时间，以提高运行效率。
群控功能	用于三台至八台电梯综合控制，充分提高电梯运行效率。
洁净抗菌功能	采用等离子杀菌技术对轿厢进行杀菌消毒，并使电梯轿厢内空气更加洁净。
能量回馈功能	将电梯运行过程中产生的再生能量回馈到用户电网，达到绿色节能效果。
地震检测功能	当用户地震检测装置动作，信号输入到系统，电梯会就近停靠，停止服务，直到地震信号消除，人工复位故障后才恢复正常。
VIP (专用) 运行	优先直驶VIP目的层，提供VIP贵宾服务。

Running Function

Fire-fighting Linkage Function	Elevator will in fire-fighting status once system receive the fire-fighting signal, feedback signal to fire-fighting center after back to fire-fighting floor.
Advanced Door Opening	When elevator enters into leveling zone, it opens door in advance, this function improves elevator running efficiency.
Double Door Independent Control	When the car has two doors, two doors can be controlled independently according to customer's request.
Re-leveling Function	When elevator lands to the current floor, due to elongation or shortening of steel rope induced by too many passengers entering into car or exiting from car, elevator will depart from leveling position, then elevator will start low speed running to achieve the leveling position again.
Duplex Control Function	This function is for two elevators' duplex control, it can reduce waiting time and improve the running efficiency.
Group Control Function	This function is for 3-8 elevators' group control, it improves the running efficiency.
Sterilization Function	Car will be fresh and clean after sterilization and disinfection by plasma sterilization technology.
Energy Feedback Function	The regeneration energy of elevator running process is contributed back to the users power grid to reach energy saving effect.
Earthquake Detection Function	When earthquake detection device (by others) acts and input signal to controller system, elevator will park to the nearest landing floor and stop service. It will return to be normal after disappearing of earthquake signal and manual reset.

人机界面

语音报站	在正常运行到站的情况下，利用语音装置告知乘客有关信息。
背景音乐	在电梯正常运行中，系统自动播放背景音乐。
轿厢副操纵箱	用于大楼中候梯人群稠密的电梯，以便让轿厢内更多的乘客方便使用。
残疾人操纵箱	安装在特殊位置和带盲文按钮的操纵箱，便于残障人士使用。
IC卡控制功能	所有(部分)层站须刷卡后电梯方可使用。

Human-Machine Interface

Voice Announcement	When elevator lands to the floor normally, voice announcement will advice passengers of the arrival.
Back Ground Music	When elevator runs normally, system will give out back ground music.
Sub-C.O.P.	It is for building with crowded passengers, it facilitates passengers to register call.
C.O.P. For Handicapped Passengers	C.O.P. with braille buttons is installed in the special position to be used by disabled persons.
IC Card Control	All (part) of the floors can be used after reading card.

应急功能

停电自动疏散装置	停电时，应急装置提供电源，电梯驶往最近层站，自动开门，疏散乘客。
----------	----------------------------------

Emergency Function

Automatic Rescue Device (ARD)	When power is off, this device supplies power to elevator, elevator runs to the nearest floor, open its door and evacuates the passengers.
-------------------------------	--

Attentive service 细心服务

高效、完善的客户服务体系， 让您无后顾之忧

在售前、售中、售后的整个过程，我们建立了高标准的服务体系，为您提供细致的售前服务指导，高效快捷的产品安装、调试等服务，给您带来便捷、安全的服务体验。同时，对售出的每一台电梯我们都将实行及时、高效地售后服务及有偿终身维修保养服务，让您的选择无后顾之忧。

Our efficient, perfect customer service system, resolve the actual difficulties.

In the whole process of pre-sale, sale and after-sale, we have established a service system of high standard to provide you with detailed pre-service guidance, efficient product installation, commissioning and other services to bring you a convenient, safe service experience. Meanwhile, we will carry out timely after-sales service and paid life-long repair & maintenance of every elevator we sold. This is our solemn guarantee to resolve actual difficulties for our customers.



For more information
please contact us!

了解更多信息，请联系